

Overview

ProtecTor



Ambient and warm air stream acting as door screening across large doorways.

Advantages

Details

Data

Video

- 1 Flow (2")
- 2 Return (2")
- 3 PowerKon heat exchanger
- 4 Whisper-quiet, sickle-blade axial fan
- 5 Discharge nozzle (shown: central discharge)
- 6 Ambient air stream
- 7 Warm air stream

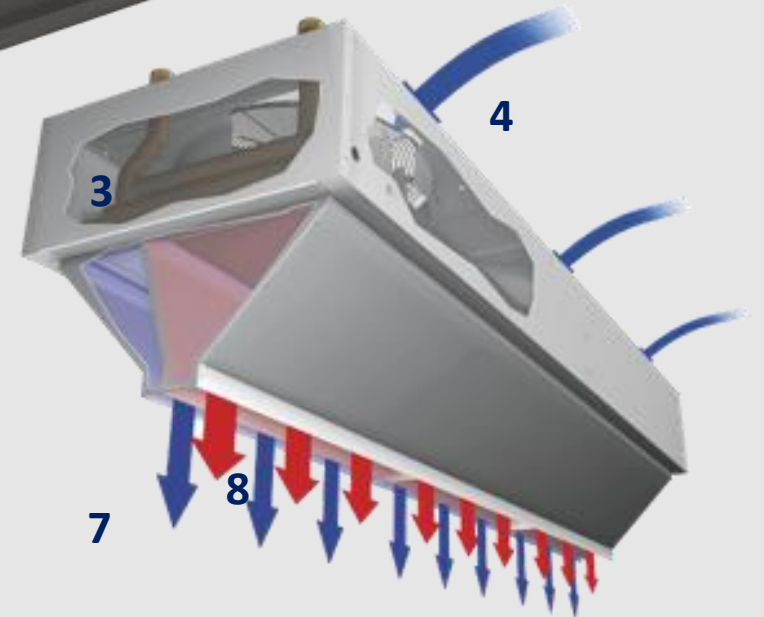
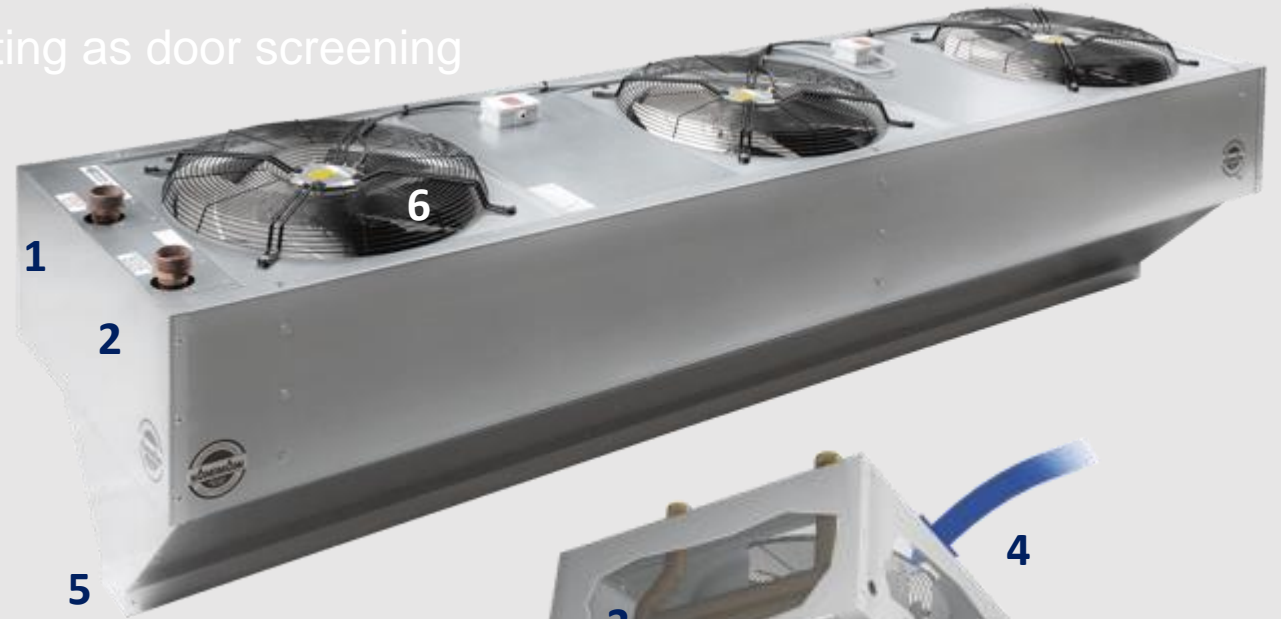

Door side

Room side



Overview

Enhanced space by doorways

Take advantage of enhanced space by improved use of space in spite of open doors, even close to doorways.

Advantages

Details

Data

Video

Invisible screening

The ProtecTor's ambient air stream and warm air stream are arranged parallel to each other, explaining why only one fan is needed to effectively screen cold air. The interior of the building remains pleasantly draught-free and warm. This technology was patented by the European Patent Office in early 2016.



Overview

Double for improved savings

The operation of ambient air stream and warm air stream creates energy savings of up to 38 percent compared to conventional systems, resulting in faster payback for your new Kampmann door air curtain. Energy-efficient EC fans also contribute to your savings.

Details

Data

Video



So many to choose from ...

Choose from vertical or horizontal installation and a range of different heat exchangers. Simply take the correct length for your narrow, wide or extra-wide doorway and you've got your perfect ProtecTor.



Overview

Perfectly controlled

The system is controlled by a stage switch combined with a door contact switch, infinitely variable speed controllers or the state-of-the-art KaControl room automation system. Of course, your special requests are also welcome!

Advantages

Details

Data

Video

Quickly delivered

Short delivery times give you flexibility and speed: Standard ProtecTor units can be on your site only seven days after technical clarification. You can rely on us. After all, your customers rely on you.



Overview

Coanda effect

- Increased penetration depth of both air streams: the ambient air stream pulls the warm air stream along with it
- Ambient air stream acts as a back-up air stream: it automatically optimises as the fan speed changes to match the warm air stream

Advantages

Details

Data

Video

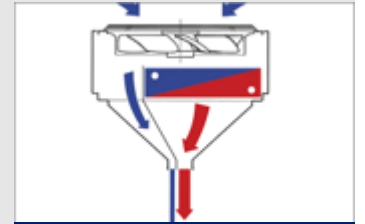
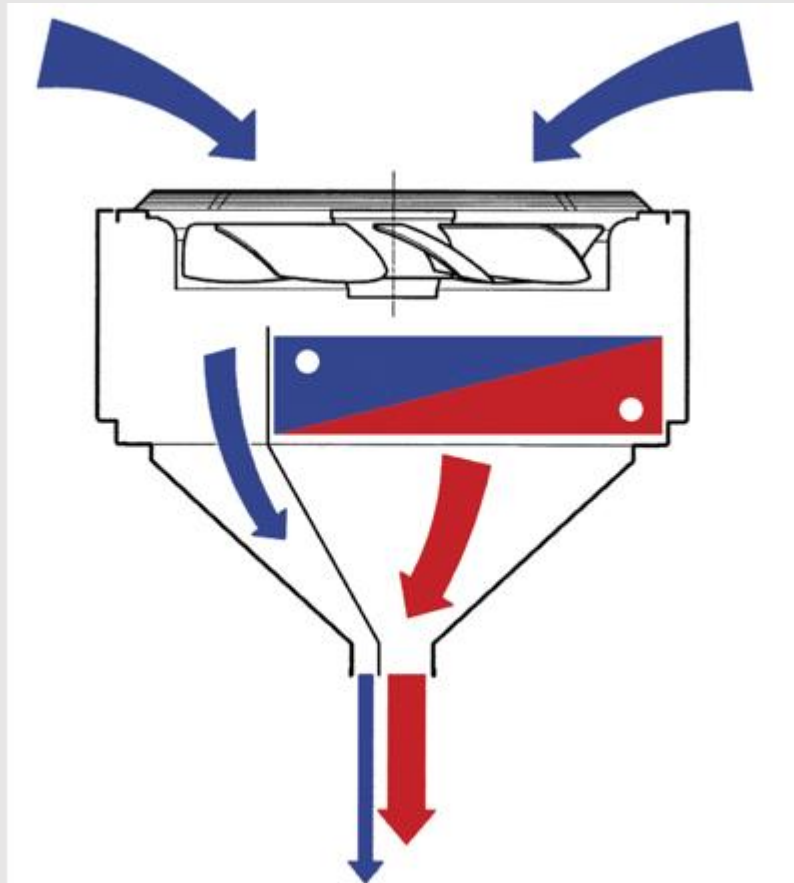

Air flow

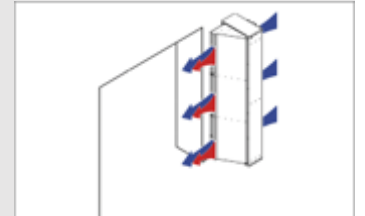

Installation options



Fan and heat exchanger

Overview

Upright model

- Air flow horizontally in front of the doorway (room side)
- Unit can stand on the right or left. Arrangement on both sides is also possible with extremely wide doorways.

Advantages

Details

Data

Video

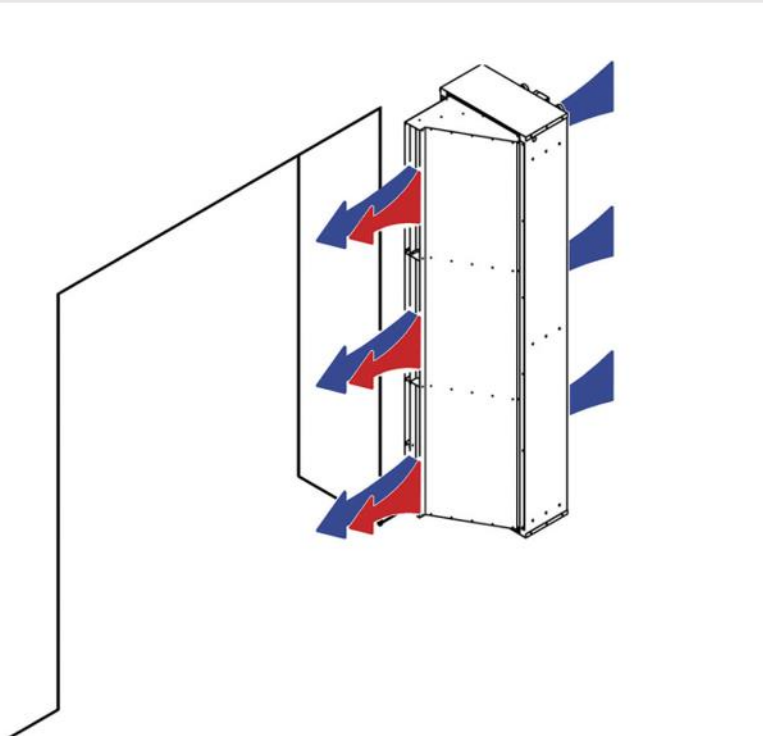

Horizontal model

- Air flow from top to bottom

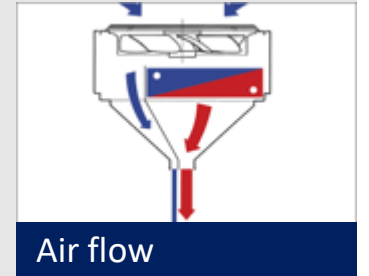
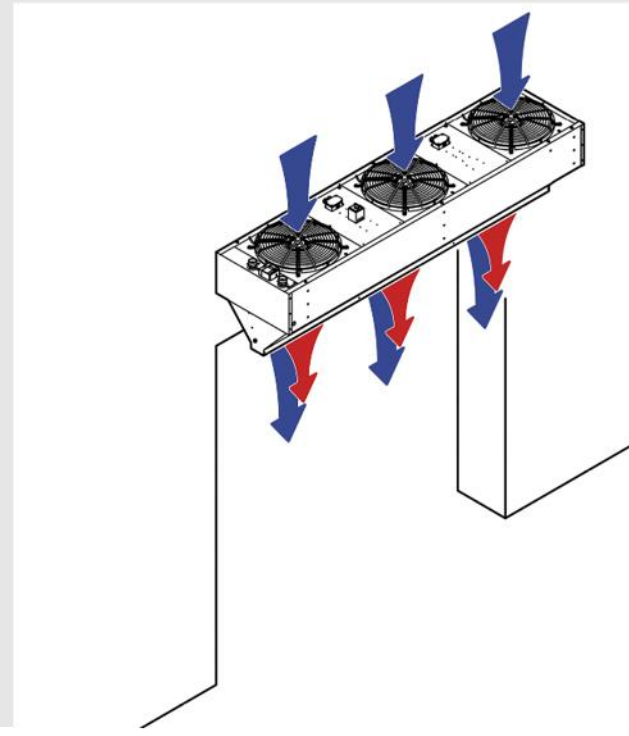

Air flow

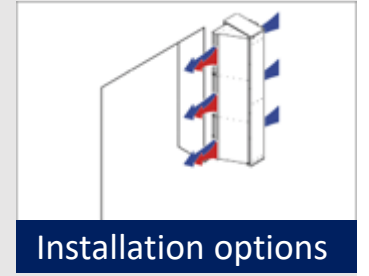

Installation options



Fan and heat exchanger

Overview

Advantages

Details

Data

Video



Whisper-quiet, sickle-blade axial fan

- 2-stage three-phase, 400V/50 Hz



PowerKon heat exchanger

- Copper pipes with profiled special aluminium fins
- Optional: Galvanised steel model

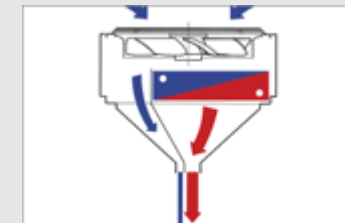

Air flow

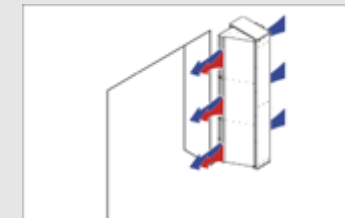

Installation options



Fan and heat exchanger



Overview

Performance data ProtecTor AC

Advantages

Details

Data

Video

Fan size	A	B	Casing height or width	Max. discharge height or width	Max. door width or height	Number of fans	Fan stage	Total air volume ²⁾	Heat output ³⁾	Sound pressure level ⁴⁾				
	[mm]	[mm]	[mm]	[m]	[m]			[m³/h]	[kW]	[dB(A)]				
6	740	2000	360	3,50	2,25	2	2	9250	43,3	61				
							1	7300	33,3	54				
		3000			3,25	3	2	13900	65,0	63				
							1	11000	50,0	56				
		4000			4,25	4	2	18500	86,7	64				
							1	14700	66,6	57				
		5000			5,25	5	2	23200	108,3	65				
							1	18300	83,3	58				
		7			840	2000	360	4,50	2,25	2	2	14350	66,7	64
											1	11950	53,0	60
3000	3,25		3	2		21500			100,3	66				
				1		17900			79,5	62				
4000	4,25		4	2		28600			133,8	67				
				1		23900			106,0	63				
5000	5,25		5	2		35800			167,2	68				
				1		29800			132,5	64				

¹⁾ Total of ambient and warm air stream ²⁾ at LPHW 75/65 °C, EAT = 20 °C ³⁾ at a distance of 5 metre



Performance data AC

Performance data EC

Dimensions

Overview

Performance data ProtecTor EC

Advantages

Details

Data

Video

Fan size	A	B	Casing height or width	Max. discharge height or width	Max. door width or height	Number of fans	Fan stage	Total air volume ²⁾	Heat output ³⁾	Sound pressure level ⁴⁾	
	[mm]	[mm]	[mm]	[m]	[m]		[V]	[m³/h]	[kW]	[dB(A)]	
6	740	2000	360	3,50	2,25	2	10	10540	47,4	63	
							6	5960	32,0	51	
						2	1700	13,5	23		
						3	10	15810	71,7	65	
							6	8940	48,0	52	
							2	2560	20,2	25	
		4			10		21080	94,9	66		
					6	11920	64,0	54			
					2	3410	27,0	26			
					5	10	26350	67,5	67		
						6	14910	45,6	55		
						2	4260	19,2	27		
7	840	2000	360	4,50		2,25	2	10	13710	64,6	64
								6	10210	52,8	58
							2	3810	26,7	36	
					3		10	20560	97,2	66	
							6	15310	79,3	59	
							2	5710	40,2	38	
		4				10	27420	130,0	67		
					6	10410	125,0	61			
					2	7620	53,7	39			
					5	10	34270	162,2	68		
						6	25520	132,4	62		
						2	9520	67,0	40		

1) Total of ambient and warm air stream 2) at LPHW 75/65 °C, EAT = 20 °C 3) at a distance of 5 metre



Performance data AC

Performance data EC

Dimensions

Overview

Dimensions

Advantages

Details

Data

Video

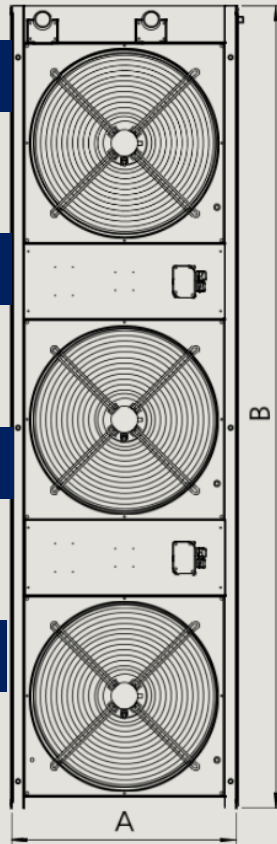

Upright model

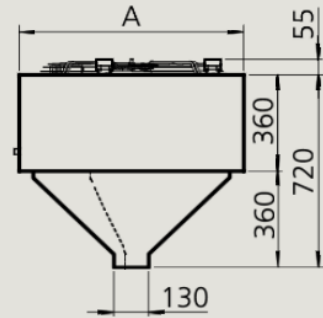

Central discharge

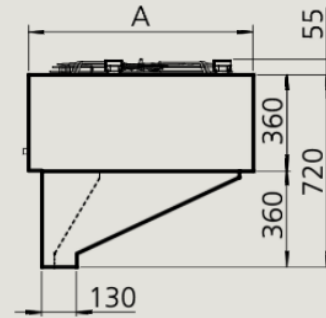

Discharge at one side

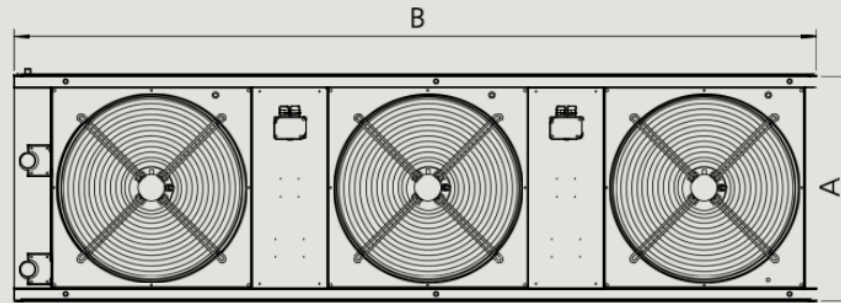

Horizontal model

Fan size	A	B
	[mm]	[mm]
6	740	3000
		4000
		5000
7	840	3000
		4000
		5000

Performance data AC

Performance data EC

Dimensions



Overview

Advantages

Details

Data

Video

without

regular

ProtecTor

